



Hewlett Packard
Enterprise

HPE OfficeConnect 1420 Switch Series

Getting Started Guide

Part number: 5200-0101R
Document version: 6W103-20160627

© Copyright 2016 Hewlett Packard Enterprise Development LP

The information contained herein is subject to change without notice. The only warranties for Hewlett Packard Enterprise products and services are set forth in the express warranty statements accompanying such products and services. Nothing herein should be construed as constituting an additional warranty. Hewlett Packard Enterprise shall not be liable for technical or editorial errors or omissions contained herein.

Confidential computer software. Valid license from Hewlett Packard Enterprise required for possession, use, or copying. Consistent with FAR 12.211 and 12.212, Commercial Computer Software, Computer Software Documentation, and Technical Data for Commercial Items are licensed to the U.S. Government under vendor's standard commercial license.

Links to third-party websites take you outside the Hewlett Packard Enterprise website. Hewlett Packard Enterprise has no control over and is not responsible for information outside the Hewlett Packard Enterprise website.

Acknowledgments

Intel®, Itanium®, Pentium®, Intel Inside®, and the Intel Inside logo are trademarks of Intel Corporation in the United States and other countries.

Microsoft® and Windows® are trademarks of the Microsoft group of companies.

Adobe® and Acrobat® are trademarks of Adobe Systems Incorporated.

Java and Oracle are registered trademarks of Oracle and/or its affiliates.

UNIX® is a registered trademark of The Open Group.

Contents

Preparing for installation	1
Safety recommendations	1
Examining the installation site	2
Temperature/humidity	2
Cleanliness	2
EMI	3
Installing the switch	4
Rack mounting	4
Horizontal surface mounting	6
Wall mounting	6
Under-table mounting	8
Connecting cables	9
Connecting network cable	9
Installing the SFP/SFP+ transceiver module and optical fibers	9
Connecting the AC power cord	10
Connecting the power adapter	10
Verifying the installation	11
Document conventions and icons	12
Conventions	12
Network topology icons	13
Support and other resources	14
Accessing Hewlett Packard Enterprise Support	14
Accessing updates	14
Websites	15
Customer self repair	15
Remote support	15
Documentation feedback	15
Appendix A Chassis views and technical specifications	17
Chassis views	17
HPE 1420 5G	17
HPE 1420 5G PoE+ (32W)	17
HPE 1420 8G	18
HPE 1420 8G PoE+ (64W)	18
HPE 1420 16G	19
HPE 1420 24G	19
HPE 1420 24G 2SFP	20
HPE 1420 24G 2SFP+	20
HPE 1420 24G PoE+ (124W)	21
Technical specifications	21
Chassis dimensions and weights	21
Ports and interface card slots	22
Environmental specifications	22
Power specifications	22
AC input voltage specifications	22
DC input voltage specifications	22
Power consumption specifications for non-PoE switches	23
Power consumption specifications for PoE switches	23
Appendix B LEDs	24
Power LED	24
Copper port LEDs	24
Fiber port LEDs	25

Preparing for installation

The HPE OfficeConnect 1420 Switch Series includes models listed in [Table 1](#).

Table 1 HPE OfficeConnect 1420 Switch Series models

Product code	HPE description	Alias	RMN
Non-PoE			
JH327A	HPE OfficeConnect 1420 5G Switch	HPE 1420 5G Switch	HNGZA-HA0026
JH329A	HPE OfficeConnect 1420 8G Switch	HPE 1420 8G Switch	HNGZA-HA0028
JH016A	HPE OfficeConnect 1420 16G Switch	HPE 1420 16G Switch	HNGZA-HA0020
JG708B	HPE OfficeConnect 1420 24G Switch	HPE 1420 24G Switch	HNGZA-HA0024
JH017A	HPE OfficeConnect 1420-24G 2SFP Switch	HPE 1420 24G 2SFP Switch	HNGZA-HA0021
JH018A	HPE OfficeConnect 1420 24G 2SFP+ Switch	HPE 1420 24G 2SFP+ Switch	HNGZA-HA0022
PoE			
JH328A	HPE OfficeConnect 1420 5G PoE+ (32W) Switch	HPE 1420 5G PoE+ (32W) Switch	HNGZA-HA0027
JH330A	HPE OfficeConnect 1420 8G PoE+ (64W) Switch	HPE 1420 8G PoE+ (64W) Switch	HNGZA-HA0029
JH019A	HPE OfficeConnect 1420 24G PoE+ (124W) Switch	HPE 1420 24G PoE+ (124W) Switch	HNGZA-HA0023

! **IMPORTANT:**

For regulatory identification purposes, the switches are assigned Regulatory Model Numbers (RMNs). The RMNs should not be confused with the marketing name HPE 1420, or the product codes.

Safety recommendations

To avoid any equipment damage or bodily injury, read the following safety recommendations before installation. The recommendations do not cover every possible hazardous condition.

- To avoid damage to the electrolytic capacitor in the switch, do not store the switch without power for more than one year.
- Before cleaning the switch, remove all power cords from the switch. Do not clean the switch with a wet cloth or liquid.
- Do not place the switch near water or in a damp environment. Prevent water or moisture from entering the switch chassis.
- Do not place the switch on an unstable case or desk. The switch might be severely damaged in case of a fall.
- Ensure good ventilation of the equipment room and keep the air inlet and outlet vents of the switch free of obstruction.
- Make sure the operating voltage is in the required range.
- To avoid electrical shocks, do not open the chassis while the switch is operating or when the switch is just powered off.

- The accessories shipped with the switch, including but not limited to power cords, are intended only for the switch. Please do not use them for other products.

Examining the installation site

The switches must be used indoors. You can mount your switch in a rack, on a horizontal surface, on a wall, or under a table. Make sure the following requirements are met:

- A minimum of 5 cm (1.97 in) of clearance is reserved at the air inlet and outlet vents for ventilation.
- The rack has a good ventilation system and the air inlet and outlet vents are not blocked when the switch is mounted under a table or on a horizontal surface.
- The rack, table, or horizontal surface is sturdy enough to support the switch and its accessories.
- The rack is reliably grounded.

To ensure correct operation and long service life of your switch, install it in an environment that meets the requirements described in the following subsections.

Temperature/humidity

Maintain temperature and humidity in the equipment room as described in "[Environmental specifications](#)."

- Lasting high relative humidity can cause poor insulation, electricity leakage, mechanical property change of materials, and metal corrosion.
- Lasting low relative humidity can cause washer contraction and ESD and cause problems including loose mounting screws and circuit failure.
- High temperature can accelerate the aging of insulation materials and significantly lower the reliability and lifespan of the switch.

Cleanliness

Dust buildup on the chassis might result in electrostatic adsorption, which causes poor contact of metal components and contact points, especially when indoor relative humidity is low. In the worst case, electrostatic adsorption can cause communication failure.

Table 2 Dust concentration limit in the equipment room

Substance	Concentration limit (particles/m ³)
Dust	$\leq 3 \times 10^4$ (no visible dust on the tabletop over three days)
NOTE: Dust diameter $\geq 5 \mu\text{m}$	

The equipment room must also meet strict limits on salts, acids, and sulfides to eliminate corrosion and premature aging of components, as shown in [Table 3](#).

Table 3 Harmful gas limits in the equipment room

Gas	Maximum concentration (mg/m ³)
SO ₂	0.2
H ₂ S	0.006
NH ₃	0.05
Cl ₂	0.01

EMI

All electromagnetic interference (EMI) sources, from outside or inside of the switch and application system, adversely affect the switch in the following ways:

- A conduction pattern of capacitance coupling.
- Inductance coupling.
- Electromagnetic wave radiation.
- Common impedance (including the grounding system) coupling.

To prevent EMI, perform the following tasks:

- If AC power is used, use a single-phase three-wire power receptacle with protection earth (PE) to filter interference from the power grid.
- Keep the switch far away from radio transmitting stations, radar stations, and high-frequency devices.
- Use electromagnetic shielding, for example, shielded interface cables, when necessary.

Installing the switch

⚠ WARNING!

Before installing or moving the switch, remove the power cord.

You can install an HPE 1420 switch in a 19-inch rack, on a horizontal surface, on a wall, or under a table.

Rack mounting

1. Wear an ESD wrist strap and make sure it makes good skin contact and is reliably grounded.
2. Verify that the rack is securely grounded and is stable.
3. Select mounting brackets for the switch.
 - The HPE 1420 16G switch uses Type-A mounting brackets, as shown in [Figure 1](#).
 - The HPE 1420 24G, 1420 24G 2SFP, 1420 24G 2SFP+, and 1420 24G PoE+ (124W) switches use Type-B mounting brackets, as shown in [Figure 2](#).
4. Attach the mounting brackets to both sides of the chassis with screws.

NOTE:

Mounting brackets are used only for securing the switch to the rack. A rack shelf on the rack is used to bear the switch weight.

Figure 1 Attaching Type-A mounting brackets to the switch

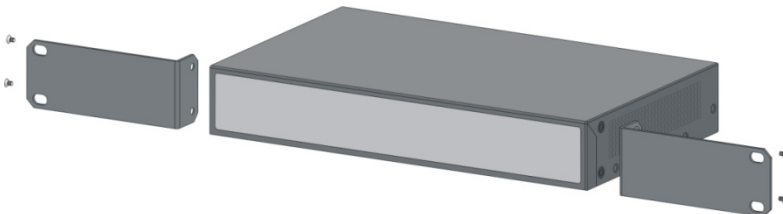
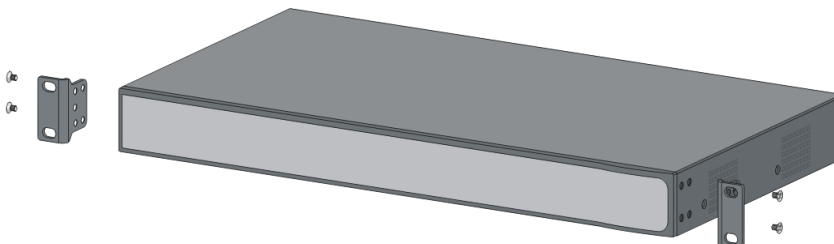

Figure 2 Attaching Type-B mounting brackets to the switch



5. Place the switch on a rack shelf in the rack. Push the switch in until the oval holes in the brackets align with the mounting holes in the rack posts.
6. Attach the mounting brackets to the rack posts with screws.

Figure 3 Attaching Type-A mounting brackets to the rack post

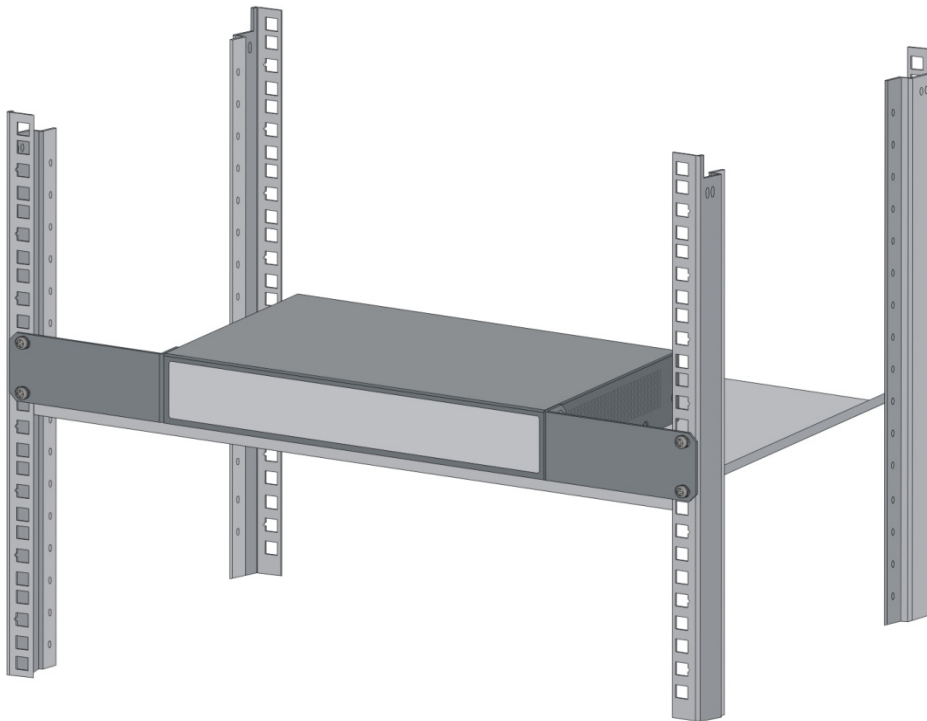
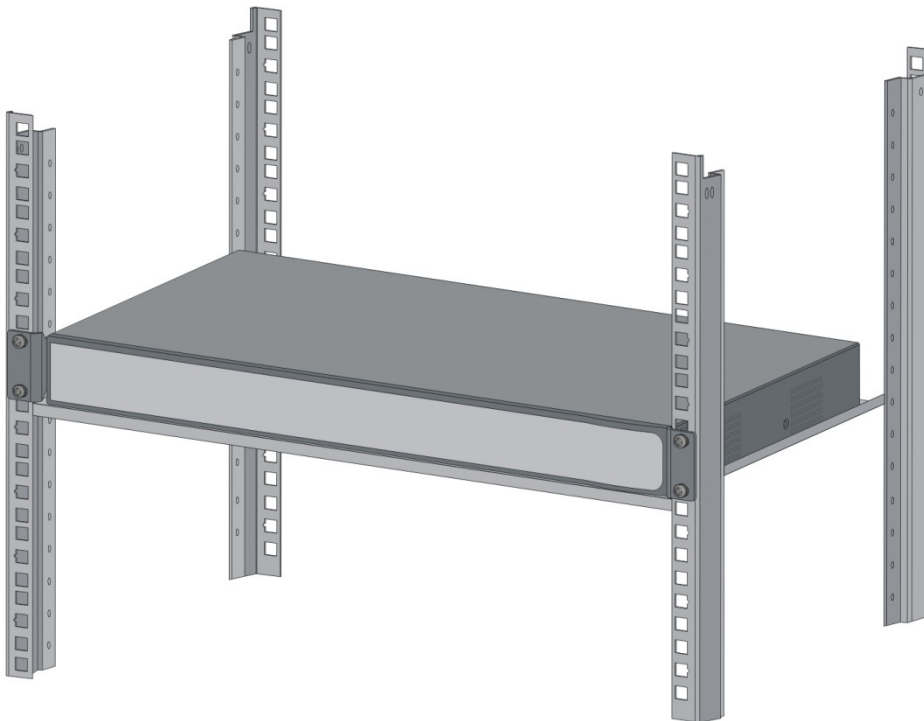

Figure 4 Attaching Type-B mounting brackets to the rack post



Horizontal surface mounting

⚠ IMPORTANT:

- Reserve a clearance of 10 cm (3.9 in) around the chassis for heat dissipation.
- Do not place heavy objects on the switch.

To mount the switch on a horizontal surface:

1. Verify that the horizontal surface is sturdy and reliably grounded.
2. Place the switch bottom up, and clean the round holes in the chassis bottom with a dry cloth.
3. Select rubber feet for the switch.
 - The HPE 1420 5G, 1420 5G PoE+ (32W), 1420 8G, 1420 8G PoE+ (64W), and 1420 16G switches use Type-A rubber feet, as shown in [Figure 5](#).
 - The HPE 1420 24G, 1420 24G 2SFP, 1420 24G 2SFP+, and 1420 24G PoE+ (124W) switches use Type-B rubber feet, as shown in [Figure 6](#).
4. Attach the rubber feet to the four round holes in the chassis bottom.
5. Place the switch upside up on the horizontal surface.

Figure 5 Attaching Type-A rubber feet

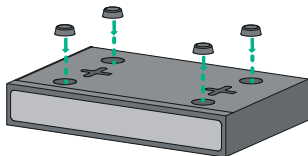
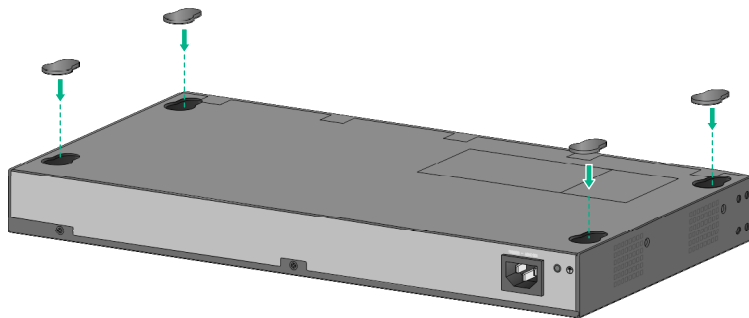

Figure 6 Attaching Type-B rubber feet



Wall mounting

Only the HPE 1420 5G, 1420 5G PoE+ (32W), 1420 8G, 1420 8G PoE+ (64W), and 1420 16G switches can be installed on a wall. The type of screws used to mount the switch on the wall depends on the wall type. This section uses a concrete wall as an example.

The screws must be a minimum of 3 mm (0.12 in) and a maximum of 3.8 mm (0.15 in) in diameter. The screw head must be a minimum of 6 mm (0.24 in) and a maximum of 9.8 mm (0.59 in) in diameter.

Figure 7 Wall-mounting anchor kit

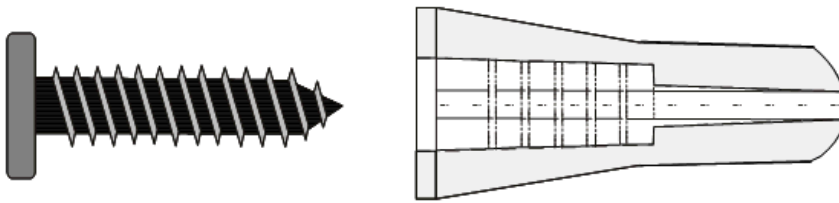

To install the switch on a concrete wall:

1. Drill two holes at the same height, as shown in [Figure 8](#).

Figure 8 Hole spacing

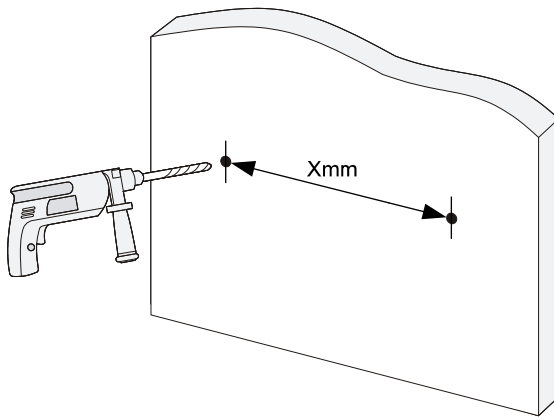

The hole depth and diameter depend on the wall anchors and screws you use. Make sure you can push the anchors to their full depth in the holes.

Installation hole spacing varies by switch model, as shown in [Table 4](#).

Table 4 Installation hole spacing requirements

Product	Installation hole spacing
HPE 1420 5G	74 mm (2.91 in)
HPE 1420 5G PoE+ (32W)	90 mm (3.54 in)
HPE 1420 8G	90 mm (3.54 in)
HPE 1420 8G PoE+ (64W)	90 mm (3.54 in)
HPE 1420 16G	160 mm (6.30 in)

2. Insert one wall anchor into each hole until the anchors are flush with the wall surface.
3. Drive one screw into each wall anchor, and tighten the screws just enough to keep it secure in the wall anchor.

Leave a minimum clearance of 1.5 mm (0.06 in) between the base of the screw head and the wall anchor so the switch can hang on the screws securely.

Figure 9 Driving a screw into a wall anchor



- Align the two mounting holes in the switch chassis bottom with the two screws on the wall and hang the switch.
Make sure the Ethernet ports are facing upwards or downwards and the chassis side panels are perpendicular to the ground.

Figure 10 Wall mounting

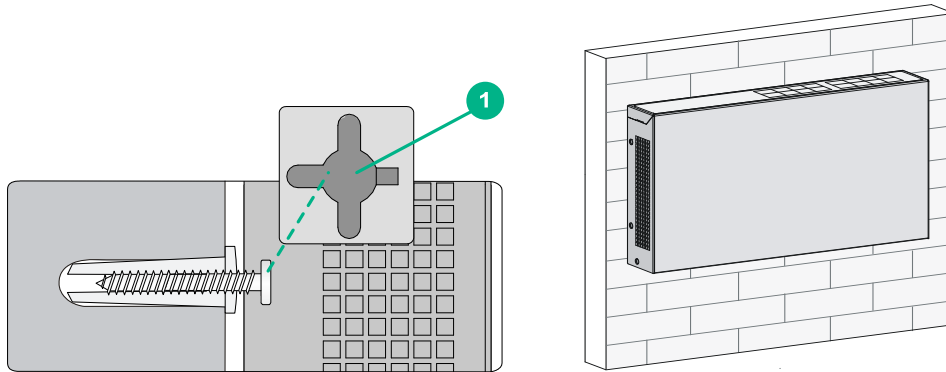

(1) Mounting hole in the switch chassis bottom

Under-table mounting

⚠ CAUTION:

- A network-attached switch with cables mounted upside down can be heavy. Verify that the table is sufficiently strong and of a material that can support the screws that hold the weight of the switch and the attached cables. Make sure the cables are protected and out of the way.
- Regularly inspect the installation of the switch to ensure that the switch remains securely anchored and unobstructed.

Only the HPE 1420 5G, 1420 5G PoE+ (32W), 1420 8G, 1420 8G PoE+ (64W), and 1420 16G switches support under-table mounting. The wall mounting screws (provided) can be used when you mount the switch under a table. This section uses the HPE 1420 16G as an example.

Figure 11 Under-table mounting

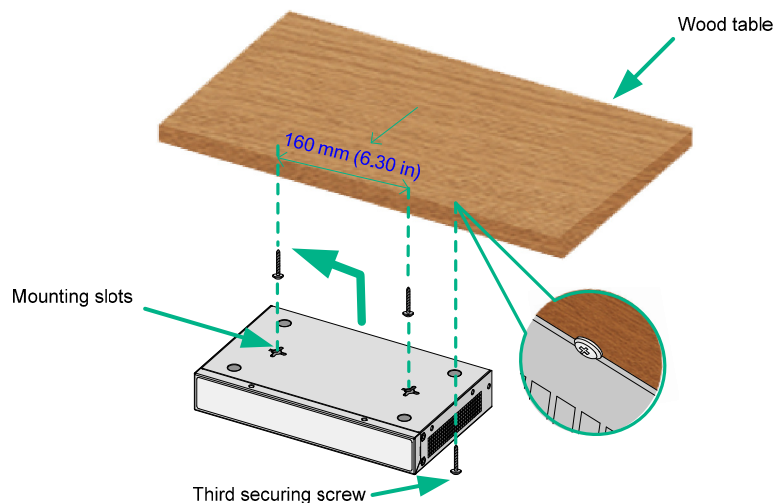

To mount the switch under a table:

1. Follow the instructions on wall mounting to determine the location of screw holes to be used for under-table mounting.
2. Align the two mounting holes in the switch chassis bottom with the two screws on the bottom of the table and hang the switch.
3. Use a third screw to prevent switch movement.

NOTE:

Installation hole spacing varies by switch model. For more information, see [Table 4](#).

Connecting cables

Connecting network cable

Use crossover cable or straight through cable to connect a PC or other network devices to the Ethernet port of the switch.

Figure 12 Connecting network cable

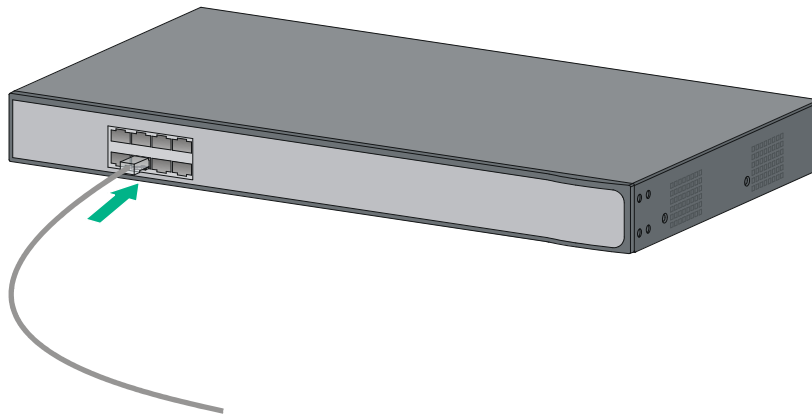

Installing the SFP/SFP+ transceiver module and optical fibers

CAUTION:

- Hold the SFP/SFP+ transceiver module by its two sides when you install or remove the module. Do not touch the golden plating of the module.
 - Remove the optical fiber, if any, from a transceiver module before installing it.
-

To install an SFP/SFP+ transceiver module and optical fibers:

1. Wear an ESD wrist strap and make sure it makes good skin contact and is reliably grounded.
2. Pivot the clasp of the module up. Holding the module, gently push the module into the slot until it has firm contact with the slot (when the top and bottom spring tabs catch in the slot).
3. Remove protective sleeves from optical fibers, and the dust plug from the transceiver module.
4. Connect the LC connectors of the optical fibers to the transceiver module.

NOTE:

- Keep the protective sleeves for future use.
 - The fiber ports on the HPE 1420 24G 2SFP Switch operate in autonegotiation mode. For the link between the switch and the peer device to operate correctly, verify that the fiber ports on the peer device also operate in autonegotiation mode.
 - For the link between the HPE 1420 24G 2SFP+ Switch and the peer device to operate correctly, set the fiber ports on both devices to operate at the same speed in full duplex mode.
-

Figure 13 Installing the SFP/SFP+ transceiver module and optical fibers

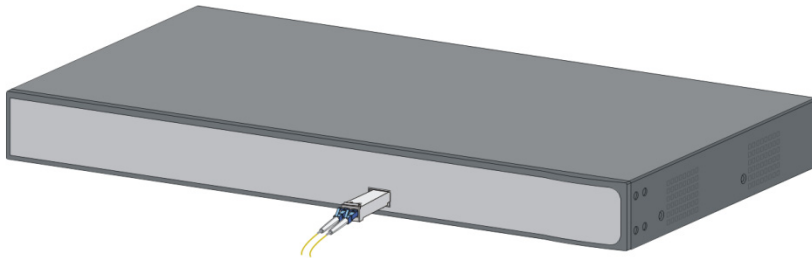

Connecting the AC power cord

Only the HPE 1420 16G, 1420 24G, 1420 24G 2SFP, 1420 24G 2SFP+, and 1420 24G PoE+ (124W) support an AC power supply.

To connect the AC power cord:

1. Wear an ESD wrist strap and make sure it makes good skin contact and is reliably grounded.
2. Connect one end of the grounding cable to the grounding screw on the rear panel, and connect the other end to the ground.
3. Make sure the correct power source is used.
4. Connect one end of the AC power cord to the AC power receptacle on the switch.
5. Connect the other end of the AC power cord to the AC power outlet.
6. Examine the power LED. If it is ON, the power connection is correct.

Figure 14 Connecting the AC power cord to the AC power receptacle

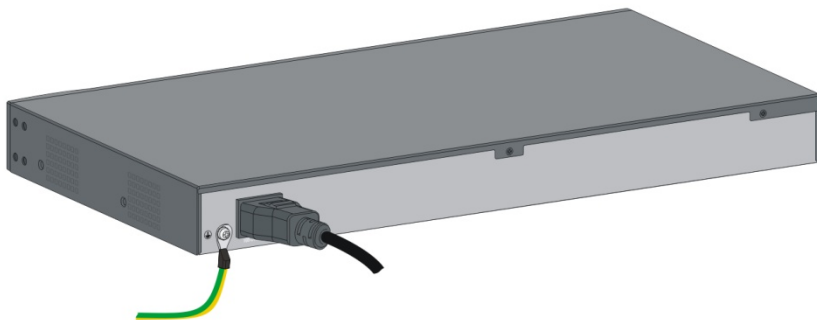

Connecting the power adapter

Only the HPE 1420 5G, 1420 5G PoE+ (32W), 1420 8G, and 1420 8G PoE+ (64W) support a power adapter. This section uses the HPE 1420 5G PoE+ (32W) as an example.

To connect the power adapter:

1. Wear an ESD wrist strap and make sure it makes good skin contact and is reliably grounded.
2. Connect one end of the grounding cable to the grounding screw on the rear panel, and connect the other end to the ground.
3. Make sure the correct power source is used.
4. Connect one end of the power adapter to the DC power receptacle on the switch.
5. Connect the other end of the power adapter to the AC power supply.
6. Examine the power LED. If it is ON, the power connection is correct.

Figure 15 Connecting the power adapter

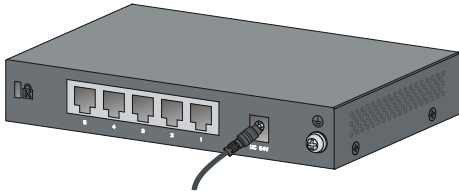

NOTE:

Hewlett Packard Enterprise recommends that you ground the HPE 1420 5G PoE+ (32W) or 1420 8G PoE+ (64W) if the PD connecting to it is grounded. The grounding cables are user supplied.

Verifying the installation

After you complete the installation, verify the following items:

- There is enough space for heat dissipation around the switch.
- The rack, table, or horizontal surface is stable.
- The grounding cable is securely connected.
- The correct power source is used.
- The power cords are correctly connected.
- All the interface cables are cabled indoors. If any cable is routed outdoors, verify that the socket strip with lightning protection and lightning arresters for network ports have been correctly connected.

Document conventions and icons

Conventions

This section describes the conventions used in the documentation.

Port numbering in examples

The port numbers in this document are for illustration only and might be unavailable on your device.





Command conventions

Convention	Description
Boldface	Bold text represents commands and keywords that you enter literally as shown.
<i>Italic</i>	<i>Italic</i> text represents arguments that you replace with actual values.
[]	Square brackets enclose syntax choices (keywords or arguments) that are optional.
{ x y ... }	Braces enclose a set of required syntax choices separated by vertical bars, from which you select one.
[x y ...]	Square brackets enclose a set of optional syntax choices separated by vertical bars, from which you select one or none.
{ x y ... }*	Asterisk marked braces enclose a set of required syntax choices separated by vertical bars, from which you select at least one.
[x y ...]*	Asterisk marked square brackets enclose optional syntax choices separated by vertical bars, from which you select one choice, multiple choices, or none.
&<1-n>	The argument or keyword and argument combination before the ampersand (&) sign can be entered 1 to n times.
#	A line that starts with a pound (#) sign is comments.













GUI conventions

Convention	Description
Boldface	Window names, button names, field names, and menu items are in Boldface. For example, the New User window appears; click OK .
>	Multi-level menus are separated by angle brackets. For example, File > Create > Folder .

Symbols

Convention	Description
 WARNING!	An alert that calls attention to important information that if not understood or followed can result in personal injury.
 CAUTION:	An alert that calls attention to important information that if not understood or followed can result in data loss, data corruption, or damage to hardware or software.
 IMPORTANT:	An alert that calls attention to essential information.
NOTE:	An alert that contains additional or supplementary information.
 TIP:	An alert that provides helpful information.

Network topology icons

Convention	Description
	Represents a generic network device, such as a router, switch, or firewall.
	Represents a routing-capable device, such as a router or Layer 3 switch.
	Represents a generic switch, such as a Layer 2 or Layer 3 switch, or a router that supports Layer 2 forwarding and other Layer 2 features.
	Represents an access controller, a unified wired-WLAN module, or the access controller engine on a unified wired-WLAN switch.
	Represents an access point.
	Represents a wireless terminator unit.
	Represents a wireless terminator.
	Represents a mesh access point.
	Represents omnidirectional signals.
	Represents directional signals.
	Represents a security product, such as a firewall, UTM, multiservice security gateway, or load balancing device.
	Represents a security card, such as a firewall, load balancing, NetStream, SSL VPN, IPS, or ACG card.

Support and other resources

Accessing Hewlett Packard Enterprise Support

- For live assistance, go to the Contact Hewlett Packard Enterprise Worldwide website:
www.hpe.com/assistance
- To access documentation and support services, go to the Hewlett Packard Enterprise Support Center website:
www.hpe.com/support/hpesc

Information to collect

- Technical support registration number (if applicable)
- Product name, model or version, and serial number
- Operating system name and version
- Firmware version
- Error messages
- Product-specific reports and logs
- Add-on products or components
- Third-party products or components

Accessing updates

- Some software products provide a mechanism for accessing software updates through the product interface. Review your product documentation to identify the recommended software update method.
- To download product updates, go to either of the following:
 - Hewlett Packard Enterprise Support Center **Get connected with updates** page:
www.hpe.com/support/e-updates
 - Software Depot website:
www.hpe.com/support/softwaredepot
- To view and update your entitlements, and to link your contracts, Care Packs, and warranties with your profile, go to the Hewlett Packard Enterprise Support Center **More Information on Access to Support Materials** page:
www.hpe.com/support/AccessToSupportMaterials

ⓘ **IMPORTANT:**

Access to some updates might require product entitlement when accessed through the Hewlett Packard Enterprise Support Center. You must have an HP Passport set up with relevant entitlements.

Websites

Website	Link
Networking websites	
Hewlett Packard Enterprise Information Library for Networking	www.hpe.com/networking/resourcefinder
Hewlett Packard Enterprise Networking website	www.hpe.com/info/networking
Hewlett Packard Enterprise My Networking website	www.hpe.com/networking/support
Hewlett Packard Enterprise My Networking Portal	www.hpe.com/networking/mynetworking
Hewlett Packard Enterprise Networking Warranty	www.hpe.com/networking/warranty
General websites	
Hewlett Packard Enterprise Information Library	www.hpe.com/info/enterprise/docs
Hewlett Packard Enterprise Support Center	www.hpe.com/support/hpesc
Hewlett Packard Enterprise Support Services Central	ssc.hpe.com/portal/site/ssc/
Contact Hewlett Packard Enterprise Worldwide	www.hpe.com/assistance
Subscription Service/Support Alerts	www.hpe.com/support/e-updates
Software Depot	www.hpe.com/support/softwaredepot
Customer Self Repair (not applicable to all devices)	www.hpe.com/support/selfrepair
Insight Remote Support (not applicable to all devices)	www.hpe.com/info/insightremotesupport/docs

Customer self repair

Hewlett Packard Enterprise customer self repair (CSR) programs allow you to repair your product. If a CSR part needs to be replaced, it will be shipped directly to you so that you can install it at your convenience. Some parts do not qualify for CSR. Your Hewlett Packard Enterprise authorized service provider will determine whether a repair can be accomplished by CSR.

For more information about CSR, contact your local service provider or go to the CSR website:

www.hpe.com/support/selfrepair

Remote support

Remote support is available with supported devices as part of your warranty, Care Pack Service, or contractual support agreement. It provides intelligent event diagnosis, and automatic, secure submission of hardware event notifications to Hewlett Packard Enterprise, which will initiate a fast and accurate resolution based on your product's service level. Hewlett Packard Enterprise strongly recommends that you register your device for remote support.

For more information and device support details, go to the following website:

www.hpe.com/info/insightremotesupport/docs

Documentation feedback

Hewlett Packard Enterprise is committed to providing documentation that meets your needs. To help us improve the documentation, send any errors, suggestions, or comments to Documentation Feedback (docsfeedback@hpe.com). When submitting your feedback, include the document title,

part number, edition, and publication date located on the front cover of the document. For online help content, include the product name, product version, help edition, and publication date located on the legal notices page.

Appendix A Chassis views and technical specifications

Chassis views

HPE 1420 5G

Figure 16 HPE 1420 5G front panel

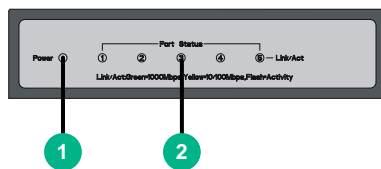

(1) Power LED

(2) Copper port LEDs

Figure 17 HPE 1420 5G rear panel

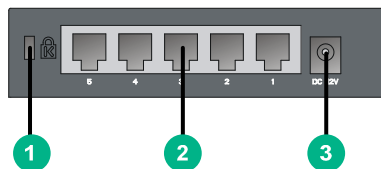

(1) Security slot

(2) 10/100/1000BASE-T copper ports

(3) DC Power receptacle

HPE 1420 5G PoE+ (32W)

Figure 18 HPE 1420 5G PoE+ (32W) front panel

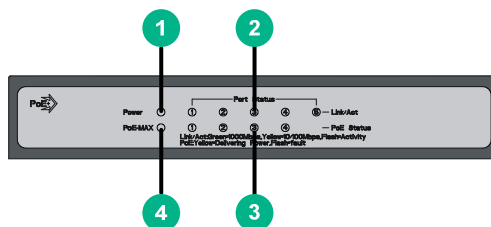

(1) Power LED

(2) Copper port LEDs

(3) PoE status LEDs

(4) PoE-MAX LED

Figure 19 HPE 1420 5G PoE+ (32W) rear panel

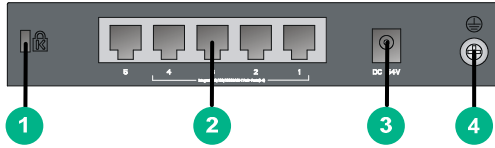

- | | |
|-------------------------|------------------------------------|
| (1) Security slot | (2) 10/100/1000BASE-T copper ports |
| (3) DC power receptacle | (4) Grounding screw |

HPE 1420 8G

Figure 20 HPE 1420 8G front panel

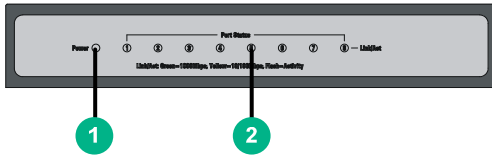

- | | |
|---------------|----------------------|
| (1) Power LED | (2) Copper port LEDs |
|---------------|----------------------|

Figure 21 HPE 1420 8G rear panel

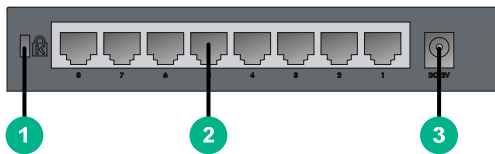

- | | |
|-------------------------|------------------------------------|
| (1) Security slot | (2) 10/100/1000BASE-T copper ports |
| (3) DC power receptacle | |

HPE 1420 8G PoE+ (64W)

Figure 22 HPE 1420 8G PoE+ (64W) front panel

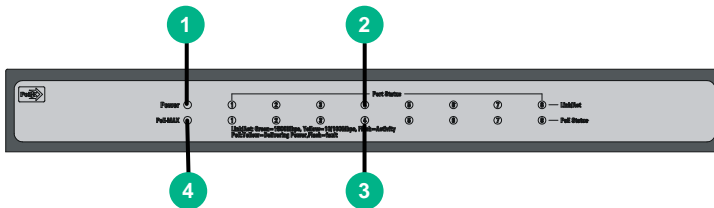

- | | |
|---------------------|----------------------|
| (1) Power LED | (2) Copper port LEDs |
| (3) PoE status LEDs | (4) PoE-MAX LED |

Figure 23 HPE 1420 8G PoE+ (64W) rear panel



- | | |
|-------------------------|------------------------------------|
| (1) Security slot | (2) 10/100/1000BASE-T copper ports |
| (3) DC power receptacle | (4) Grounding screw |

HPE 1420 16G

Figure 24 HPE 1420 16G front panel

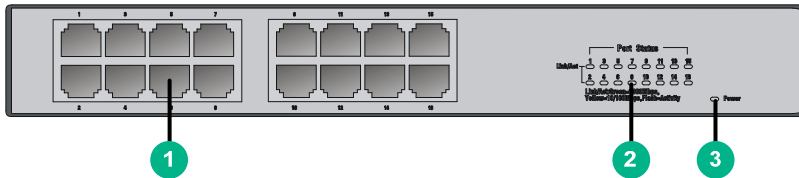

- | | |
|------------------------------------|----------------------|
| (1) 10/100/1000BASE-T copper ports | (2) Copper port LEDs |
| (3) Power LED | |

Figure 25 HPE 1420 16G rear panel



- | | |
|---------------------|-------------------------|
| (1) Grounding screw | (2) AC power receptacle |
|---------------------|-------------------------|

HPE 1420 24G

Figure 26 HPE 1420 24G front panel



- | | |
|------------------------------------|----------------------|
| (1) 10/100/1000BASE-T copper ports | (2) Copper port LEDs |
| (3) Power LED | |

Figure 27 HPE 1420 24G rear panel

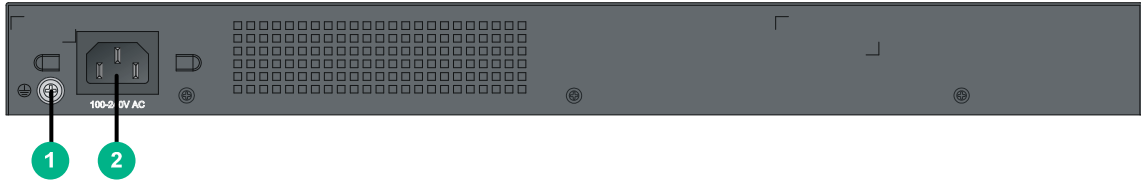

(1) Grounding screw

(2) AC power receptacle

HPE 1420 24G 2SFP

Figure 28 HPE 1420 24G 2SFP front panel

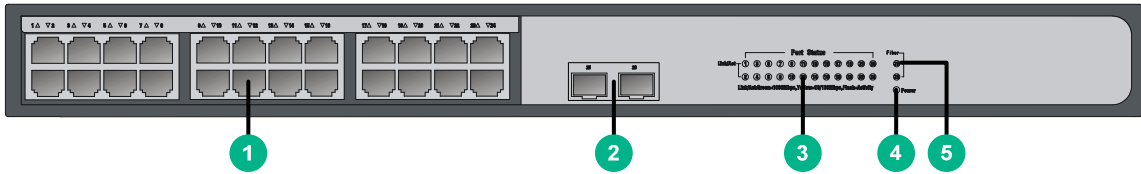

(1) 10/100/1000BASE-T copper ports

(2) 100/1000BASE-X SFP fiber ports

(3) Copper port LEDs

(4) Power LED

(5) Fiber port LEDs

Figure 29 HPE 1420 24G 2SFP rear panel

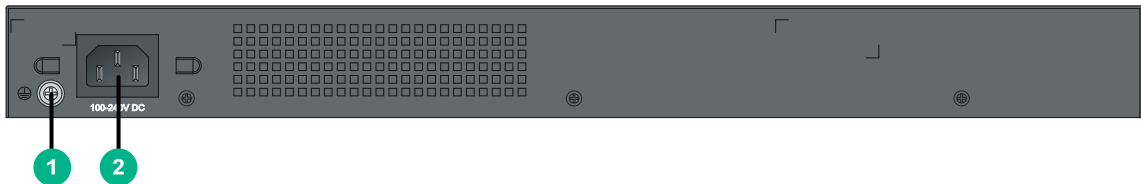

(1) Grounding screw

(2) AC power receptacle

HPE 1420 24G 2SFP+

Figure 30 HPE 1420 24G 2SFP+ front panel

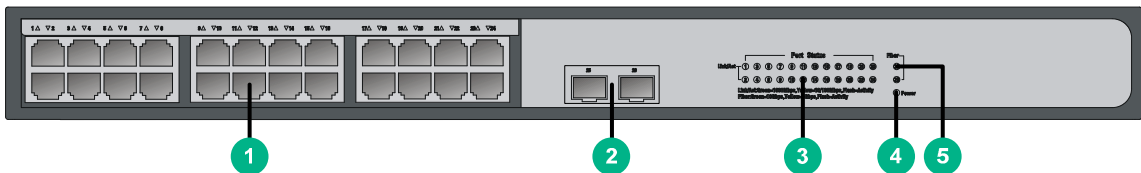

(1) 10/100/1000BASE-T copper ports

(2) 1000BASE-X SFP/10GBASE-SR/LR SFP+ ports

(3) Copper port LEDs

(4) Power LED

(5) Fiber port LEDs

Figure 31 HPE 1420 24G 2SFP+ rear panel

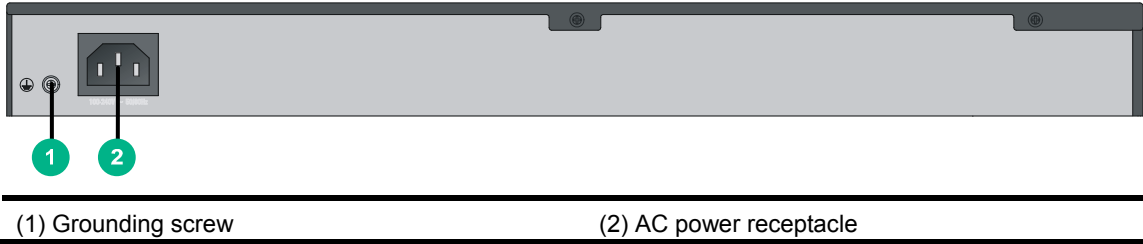

- (1) Grounding screw (2) AC power receptacle

HPE 1420 24G PoE+ (124W)

Figure 32 HPE 1420 24G PoE+ (124W) front panel



- (1) 10/100/1000BASE-T copper ports (1 to 12 are PoE ports) (2) PoE status LEDs
 (3) PoE-MAX LED (4) Copper port LEDs
 (5) Power LED

Figure 33 HPE 1420 24G PoE+ (124W) rear panel

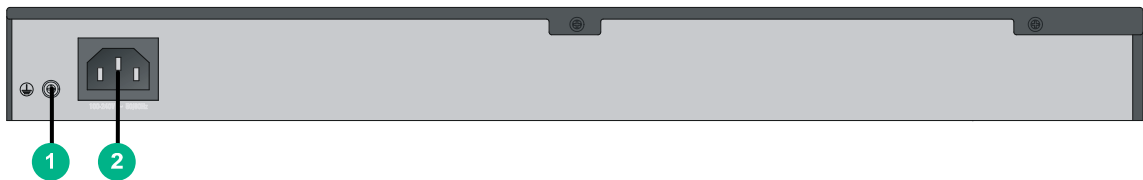

- (1) Grounding screw (2) AC power receptacle

Technical specifications

Chassis dimensions and weights

Chassis	Dimensions (H x W x D)	Maximum weight
HPE 1420 5G	27 x 115 x 81 mm (1.06 x 4.52 x 3.18 in)	0.3 kg (0.66 lb)
HPE 1420 5G PoE+ (32W)	27 x 158 x 105 mm (1.06 x 6.21 x 4.13 in)	0.5 kg (1.10 lb)
HPE 1420 8G	27 x 158 x 105 mm (1.06 x 6.21 x 4.13 in)	0.5 kg (1.10 lb)
HPE 1420 8G PoE+ (64W)	27 x 235 x 105 mm (1.06 x 9.24 x 4.13 in)	0.7 kg (1.54 lb)
HPE 1420 16G	44 x 266 x 162 mm (1.73 x 10.47 x 6.38 in)	1.2 kg (2.65 lb)
HPE 1420 24G	44 x 440 x 173 mm (1.73 x 17.32 x 6.81 in)	2.2 kg (4.85 lb)
HPE 1420 24G 2SFP	44 x 440 x 173 mm (1.73 x 17.32 x 6.81 in)	2.2 kg (4.85 lb)
HPE 1420 24G 2SFP+	44 x 440 x 238 mm (1.73 x 17.32 x 9.37 in)	2.9 kg (6.39 lb)
HPE 1420 24G PoE+ (124W)	44 x 440 x 238 mm (1.73 x 17.32 x 9.37 in)	3.3 kg (7.28 lb)

Ports and interface card slots

Chassis	10/100/1000BASE-T auto-sensing Ethernet ports	100/1000BASE-X SFP ports	1000BASE-X SFP/10GBASE-SR/LR SFP+
HPE 1420 5G	5	0	0
HPE 1420 5G PoE+ (32W)	5 (1 to 4 are PoE ports), PoE+	0	0
HPE 1420 8G	8	0	0
HPE 1420 8G PoE+ (64W)	8 (1 to 8 are PoE ports), PoE+	0	0
HPE 1420 16G	16	0	0
HPE 1420 24G	24	0	0
HPE 1420 24G 2SFP	24	2	0
HPE 1420 24G 2SFP+	24	0	2
HPE 1420 24G PoE+ (124W)	24 (1 to 12 are PoE ports), PoE+	0	0

Environmental specifications

Chassis	Operating temperature	Relative humidity
All chassis	0°C to 40°C (32°F to 104°F)	5% to 95%, noncondensing

Power specifications

AC input voltage specifications

Chassis	Rated voltage range
HPE 1420 16G	100 VAC to 240 VAC @ 50 Hz or 60 Hz
HPE 1420 24G	100 VAC to 240 VAC @ 50 Hz or 60 Hz
HPE 1420 24G 2SFP	100 VAC to 240 VAC @ 50 Hz or 60 Hz
HPE 1420 24G 2SFP+	100 VAC to 240 VAC @ 50 Hz or 60 Hz
HPE 1420 24G PoE+ (124W)	100 VAC to 240 VAC @ 50 Hz or 60 Hz

DC input voltage specifications

Chassis	Voltage
HPE 1420 5G	12V DC
HPE 1420 5G PoE+ (32W)	54V DC

Chassis	Voltage
HPE 1420 8G	12V DC
HPE 1420 8G PoE+ (64W)	54V DC

Power consumption specifications for non-PoE switches

Chassis	Min. power consumption	Max. power consumption
HPE 1420 5G	1 W	3 W
HPE 1420 8G	1 W	4.5 W
HPE 1420 16G	6.8 W	12 W
HPE 1420 24G	8 W	16 W
HPE 1420 24G 2SFP	7 W	18 W
HPE 1420 24G 2SFP+	9.5 W	21 W

Power consumption specifications for PoE switches

Chassis	Max. PoE power per port	Max. PoE ports at full 30 W output	Total PoE output	Min. power consumption	Max. power consumption (including total PoE output)
HPE 1420 5G PoE+ (32W)	30 W	1	32 W	5 W	40 W
HPE 1420 8G PoE+ (64W)	30 W	2	64 W	5 W	80 W
HPE 1420 24G PoE+ (124W)	30 W	4	124 W	10.5 W	160 W

Appendix B LEDs

Power LED

Table 5 Power LED description

Status	Description
Steady green	The switch is powered on and the power supply is operating correctly.
Flashing green	The switch is powered on and is performing the self-test. The switch is faulty if the LED flashes green for five seconds.
Off	The switch is not powered on or the power supply is faulty.

Copper port LEDs

Link/ACT LEDs

Table 6 Link/ACT LED description

Status	Description
Steady yellow	A 10/100-Mbps link is present.
Flashing yellow	The port is receiving or sending data at 10/100 Mbps.
Steady green	A 1000-Mbps link is present.
Flashing green	The port is receiving or sending data at 1000 Mbps.
Off	No link is present.

PoE LEDs

Table 7 PoE status LED description

Status	Description
Steady yellow	The port is supplying power correctly.
Flashing yellow	The port is supplying power incorrectly.
Off	The port is not supplying power.

Table 8 PoE-MAX LED description(HPE 1420 5G PoE+ (32W))

Status	Description
Steady yellow	The PoE power reaches the guard band (16 W to 32 W).
Off	The PoE power does not reach 16 W.

Table 9 PoE-MAX LED description(HPE 1420 8G PoE+ (64W))

Status	Description
Steady yellow	The PoE power reaches the guard band (48 W to 64 W).
Off	The PoE power does not reach 48 W.

Table 10 PoE-MAX LED description(HPE 1420 24G PoE+ (124W))

Status	Description
Steady yellow	The PoE power reaches the guard band (104 W to 124 W).
Off	The PoE power does not reach 104 W.

NOTE:

A port with a smaller port ID has a higher priority for getting power. When the PoE power reaches the guard band and a new port requires power, the switch compares the port IDs and performs one of the following actions:

- Does not supply power to the new port if the ID of the new port is greater than IDs of all existing ports.
- Stops power supply to existing ports whose IDs are greater than the ID of the new port, and supplies power to the new port.

Fiber port LEDs

Table 11 SFP port LED description

Status	Description
Steady yellow	A 100-Mbps link is present.
Flashing yellow	The port is receiving or sending data at 100 Mbps.
Steady green	A 1000-Mbps link is present.
Flashing green	The port is receiving or sending data at 1000 Mbps.
Off	No link is present.

Table 12 SFP+ port LED description

Status	Description
Steady yellow	A 1000-Mbps link is present.
Flashing yellow	The port is receiving or sending data at 1000 Mbps.
Steady green	A 10-Gbps link is present.
Flashing green	The port is receiving or sending data at 10 Gbps.
Off	No link is present.

Appendix C Troubleshooting

Table 13 describes the troubleshooting methods for common issues that you might encounter while using and managing the switch.

If a problem persists, contact Hewlett Packard Enterprise Support.

Table 13 Troubleshooting methods

Symptom	Troubleshooting method
Power LED off	<ol style="list-style-type: none">1. Verify that the correct power source is used and the power cords are correctly connected.2. Verify that the power source side provides power supply correctly.
LAN interface LED off	<ol style="list-style-type: none">1. Verify that the network cable is correctly connected to the network port of the switch.2. Insert the two ends of a network cable into two network ports of the switch. If the port LEDs are off, replace the network cable.